

160mJ Laser Target Designator with Rangefinder

Model:JIO-Z160M



Overview

This technical specification specifies the main functions, main technical indexes and other elements of JIO-Z160M laser photometer. JIO-Z160M LDR is composed of laser emission unit, laser receiving and ranging unit, laser driving source and control and communication unit.

Main function

- Laser ranging function;
- Laser irradiation function;
- photoelectric isolation signal trigger;
- disassembled aiming beam ;
- external trigger function;

Main technical indicators

Model	JIO-Z160M
Working wavelength	1064nm±1nm
Laser irradiation energy	Both 85mj and 160mj can be switched
Light delay	304µs±1µs
Laser beam dispersion Angle	≤0.2mrad
Irradiation frequency	8 ~ 21Hz

Ranging frequency	10Hz	
Laser pulse width	10ns ~15ns	
Power stability	≤±8%	
Ranging range	0.2m ~ 30km (target size 10 m *10 m *8 m, visibility 30km)	
Ranging error	less than or equal to 5 meters	
Target selection	first/second/end	
Accurate measurement rate	98%	
Start-up time	<1min (at normal temperature)	
Working time	Ranging mode	continuously working for 5min, rest for 4min, continuous 5 cycles (at low/normal temperature) continuously working for 5min, rest for 4min, continuous 2cycles (at high temperature and 85mj output) continuously working for 2 min, rest for 4min, continuous 2cycles (at high temperature and 160mj output)
	Irradiation mode	irradiation time 90s, rest 60s, continuous 5 cycles (at low/normal temperature and 85mj output) irradiation time 60s, rest 60s, continuous 5 cycles (at low/normal temperature and 160mj output) irradiation time 90s, rest 60s, continuous 1 cycles (at high temperature and 85mj output) irradiation time 60s, rest 60s, continuous 1 cycles (at high temperature and 160mj output)
Full set weight	≤ 3.3kg	

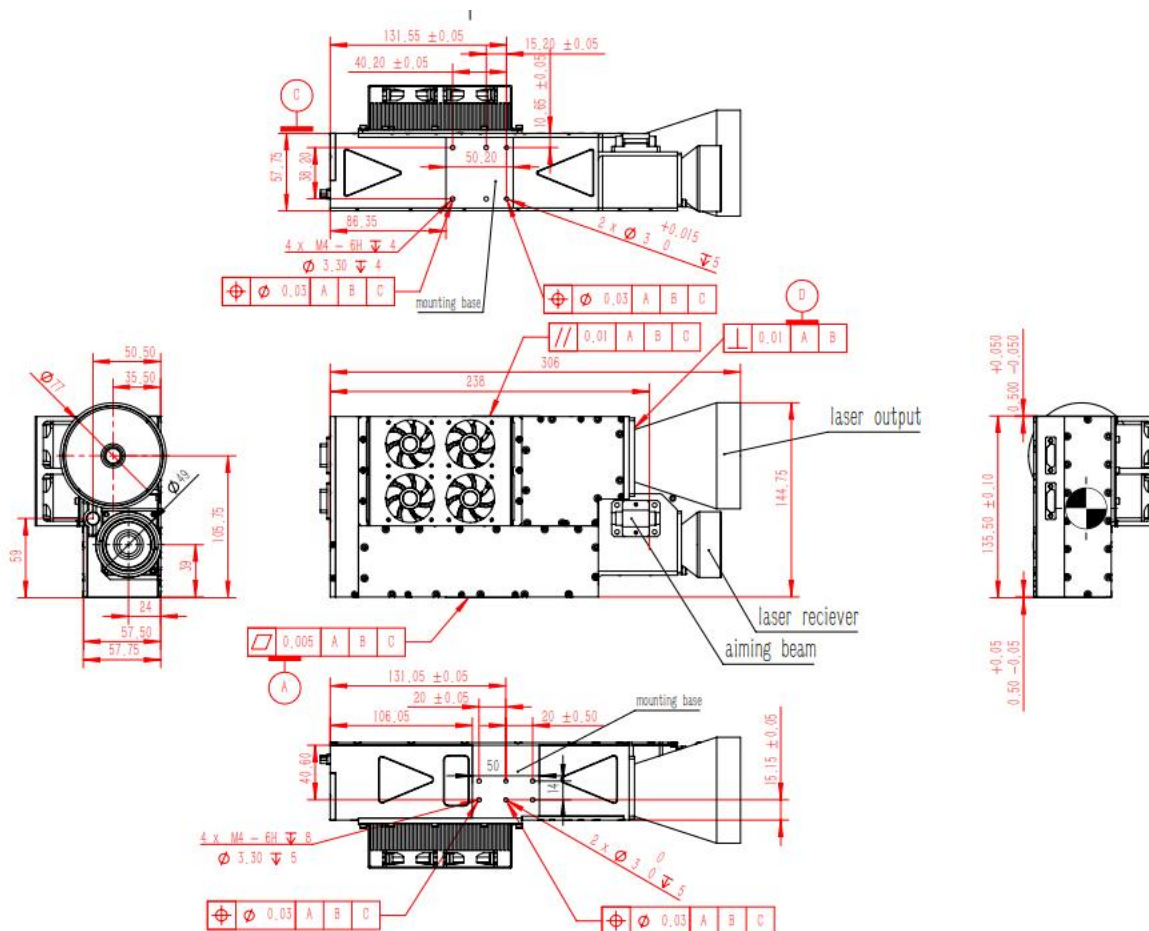

Electrical interface

1. Communication connector (socket model J30J-15ZKP, butt plug model J30J-15TJ) Pin definition

Pin	Definition	Content	Type of signal	Remarks
1	TX+	RS422 Send positive (local)	Output	Object host computer
2	TX -	RS422 Send negative (local)	Output	Object host computer
3	RX+	RS422 Receive positive (local)	Input	Object upper computer
4	RX -	RS422 Receive negative (local)	Input	Object upper computer
5	GND	Ground RS422	Signal ground	Object upper computer
6				Manufacturer's debug special
7				Manufacturer's debug special
8				Manufacturer's debug special
9				Manufacturer's debug special
10				Manufacturer's debug special
11				Manufacturer's debug special
12				Manufacturer's debug special
13				Manufacturer's debug special
14		External time system +	Input	RS422 differential
15		External time system -	Input	RS422 differential

2. Power connector (plug type J30J02P020P000S0P120, plug type J30J02P020S000S0L000) Pin definition

Pin Number	Definition	Remarks
A, B	24V	The wire color is red
C, D	GND	The wire color is black

Key performance indicators

Power supply and power consumption	Power supply range	20V ~ 33V, DC
	Power consumption	peak power is not more than 260W, standby power is not more than 60W (normal temperature)
Reliability	MTBF is not less than 4000h (total firing time is larger than 3 millions)	
Security	Set up a warning device for the laser to work	
	The exit of the laser transmitter is provided with obvious warning signs	
	The equipment is well grounded	
Maintainability	All major functional components and equipment have both fault indicators and indicators for normal operation	
	The average repair time MTTR is not more than 20min	
Electromagnetic compatibility requirements	In the system boot-up process, the equipment can be compatible with other equipment in the system and operate normally	

Environmental adaptability requirements

Temperature	Operating temperature	-40°C ~ +60°C
	Storage temperature	-40°C ~ +70°C

Humid heat	Relative humidity	95% ± 3%	
	Temperature	+25°C±2°C	
	Storage time	72h	
Vibration	Vibration spectrum shape (grms=6.06)	20Hz to 80Hz	+3dB/oct
		80Hz to 350Hz	G2/0.04 Hz
		350Hz to 2000Hz	-3dB/oct
	Vibration direction and time	vibrate in two direction for at least 10min	
	Control point	should be selected in the fixture or shaking table surface near the maximum stiffness of the product, large equipment can use multi-point average control	
	Monitoring point	the monitoring point should be selected in the key part of the product under test, so that the root mean square acceleration response does not exceed the maximum allowable design (grms=6.06)	
	Installation requirements	The specimen is firmly attached to the shaking table, and for products equipped with shock absorbers, the shock absorbers should be removed before testing	
Performance check	During vibration testing with the equipment powered on, all performance indicators must meet the technical requirements specified in the design document. In the event of a failure, repairs are allowed. After the repair, the spectral value should be reduced to 0.01g ² /Hz, grms=3.03, and the specimen should be subjected to vibration in the direction most susceptible to vibration for 10 minutes during the acceptance test.		
Temperature cycle	Temperature range	Power-on test	-35±3°C ~ +52±2°C
	Rate of temperature change	Temperature rise	10°C/min
		Cooling	10°C/min
	Cycle times	Ten cycles should be completed, ensuring that the last 2 cycles are without faults. If a fault occurs during the last 2 cycles, after repairs, an additional 2 fault-free cycles are required.	
	Cycle time	One cycle time is 4h, one cycle includes temperature rise → temperature stay → cooling → temperature stay → temperature rise	
	High and low temperature residence time	the residence time depends on the heat capacity of the specimen. Based on the principle of product thermal or cold permeability, the internal temperature of the specimen is maintained for 5min after reaching stability	
	The requirements of the product under test	general temperature cycle test with the whole machine, should be as far as possible to open the cover	
Check and repair	In the power test equipment, after each temperature cycle test, it is		

		necessary to confirm that the equipment is free of faults before proceeding to the next temperature cycle	
Drenching requirements	Drenching is carried out with the whole equipment		
transportation requirements	Equipment needs to be transported as a whole vehicle		
	If the product has not undergone a road transport test, you can perform an indoor transport simulation test using a simulation transport table. This test involves conducting a sinusoidal cyclic vibration test to assess the product's performance		
	The requirements of the simulated transport table test are as follows		
	Test conditions	Frequency	5Hz ~ 200Hz
		Amplitude	5Hz ~ 7Hz
		Amplitude 12mm ~ 8mm	
		7Hz ~ 200Hz equal acceleration 1.5g	
	Vibration test condition allowable deviation is the same as broadband random vibration test		
	Direction	vertical axle direction and side;Orientation: vertical and lateral to the axle	
Cycle time	log-scan 5Hz ~ 200Hz ~ 5Hz, 12min per cycle;When the resonant frequency of the specimen is measured below 5Hz, the test frequency can be extended to 2Hz, 2Hz ~ 200Hz ~ 2Hz scanning, scanning time should be 15min.The vibration time in each direction is 90min		
After the transportation test, check for any signs of damage or structural loosening, and conduct an inspection of technical indices to ensure they meet the design requirements			